

RETRACTED

# HAMK | Unlimited

(<https://unlimited.hamk.fi/>)

## From Pyrolysis to FiksuHiili



*Photo by Sam Whitley, HAMK.*

Daniel Kelly & Valerii Matveev

07.06.2023



Biochar has many benefits such as soil water retention (Ayodele et al., 2009) but the production of it can be quite expensive. Is there a more efficient and cheaper way to produce this precious resource? HAMK Tech research unit at Häme University of Applied Sciences (HAMK) is on the mission to answer this question via the FiksuHiili project.

The FiksuHiili Project that is being undertaken by HAMK Tech research unit in collaboration with the HAMK Bio research unit, aims to provide a solution for producing biochar by using a modified boiler. Upon completion of the project, the goal is to have a cost-effective system that is fully or semi-autonomous, scalable, reproducible and can efficiently produce biochar in a continuous manner.

The Veto 60 boiler (figure 1) is a traditional biomass boiler that operates on solid fuel biomass and can generate up to 60kW of power. It is suitable for heating single detached homes and small properties such as farms. (Ala-Talkkari, n.d.)

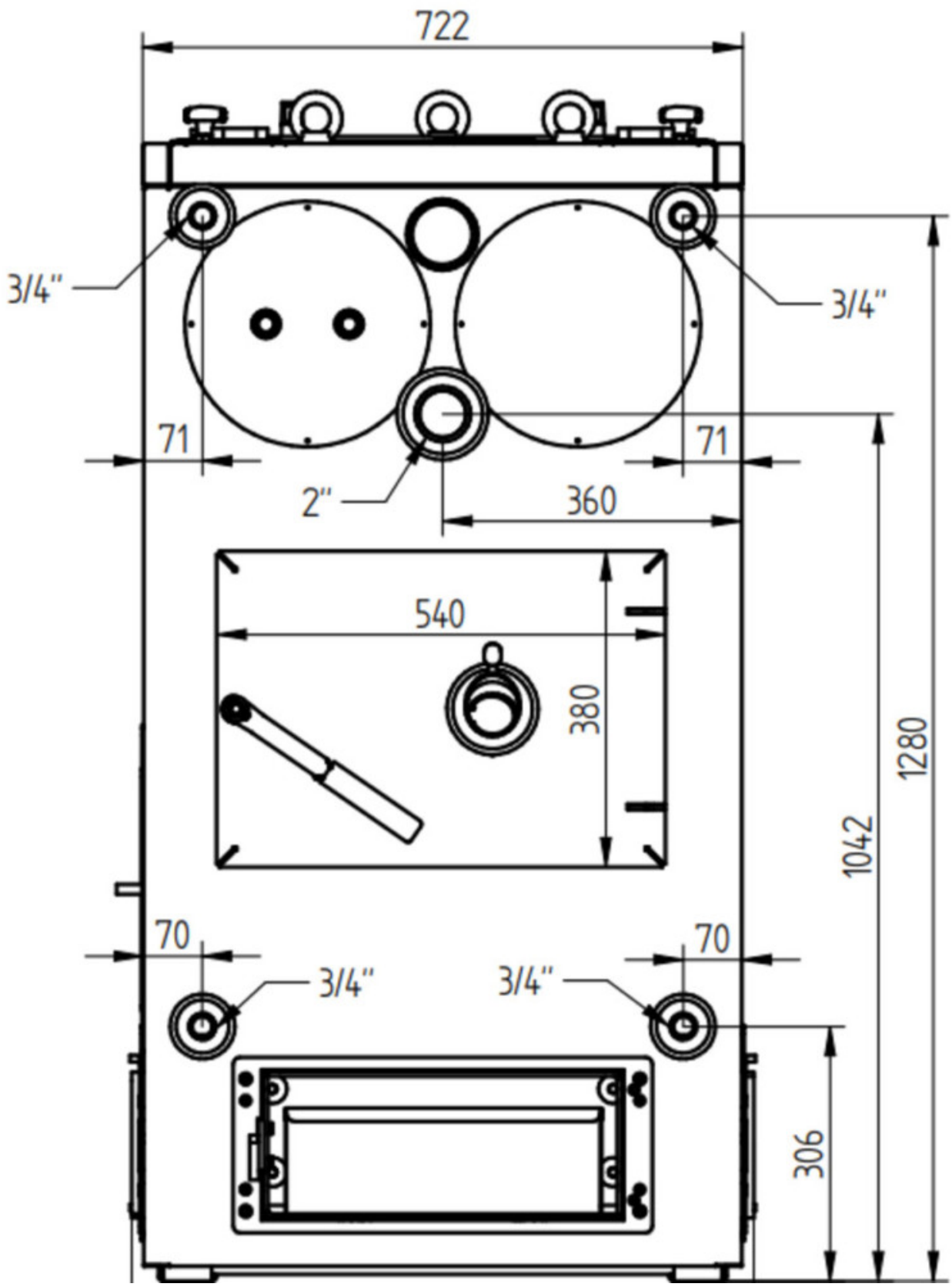

Figure 1. Schematic of the Veto 60kW boiler from the front (Ala-Talkkari, n.d.).

To facilitate the production of biochar, modifications were made to the boiler including a door extension, additional door insulation and the use of acid resistant stainless steel for the reactor pipe. The reactor pipe or simply the reactor is the sealed vessel inside which the process of pyrolysis will occur in the absence of oxygen (Ralebitso-Senior & Orr, 2016). These modifications have been made to the boiler and have proven to be effective during pyrolysis.

According to the International Biochar Initiative (n.d.), biochar is the solid material obtained when biomass has been thermochemically converted in an oxygen-limited environment at temperatures lower than 700 degrees Celsius. The principle of pyrolysis is the decomposition of biomaterial at high temperatures, and one of the project's aims is to produce biochar by thermal decomposition of various types of biomass. The biomass must be heated to temperatures between 250 °C – 500 °C (Wang & Luo, 2016). The desired temperatures of more than 500 °C were achieved by using a hot air blower by the manufacturer Leister. During burning trials that occurred from December 2022 to January 2023, wood chips were used as the biomass and they were heated to temperatures in the range of 500 to 610°C.

An important part of the pyrolysis process is the residence time. The residence time is the amount of time that the biomass will be or has been inside the reactor (Solar et al., 2016). The residence time can vary from a few seconds to hours depending on the intensity of the heat source used and factors such as the quantity of biomass and its humidity. On average, the mass of biomass used was 806 grams and the humidity was 5%. The reaction time for burning tests varied between 0 to 15 minutes.

Currently, there is no specific time for how long the biomass should be inside the reactor because that depends on the desired output, the material, and the heat source so for the time being, many trials must be done to determine a specific time value. Cooling is also another important segment of the pyrolysis process, and that part of the process is still being investigated and a few suggestions have already been made. For example, one suggestion was that tubes with cold water would be wrapped around the biochar removal pipe and this cold water would be circulated using a pump.

## Modification of the boiler

The door of the boiler has been extended (figure 2) with a stainless-steel pipe to facilitate more residence time for the biomass and to improve the drying process. The drying of the biomass is a crucial step because it helps to ensure efficient biochar formation. The extended door facilitates an increased contact time with the walls of the pipe whereby heat is transferred.

When designing the reactor, a curved design was used so that the space available inside the boiler could be efficiently used. Thus, it enabled the fire to have direct contact with the outside of the reactor which formed the biochar. Additionally, acid resistant stainless steel was chosen as the material for the reactor pipe to avoid corrosion after gases were released.

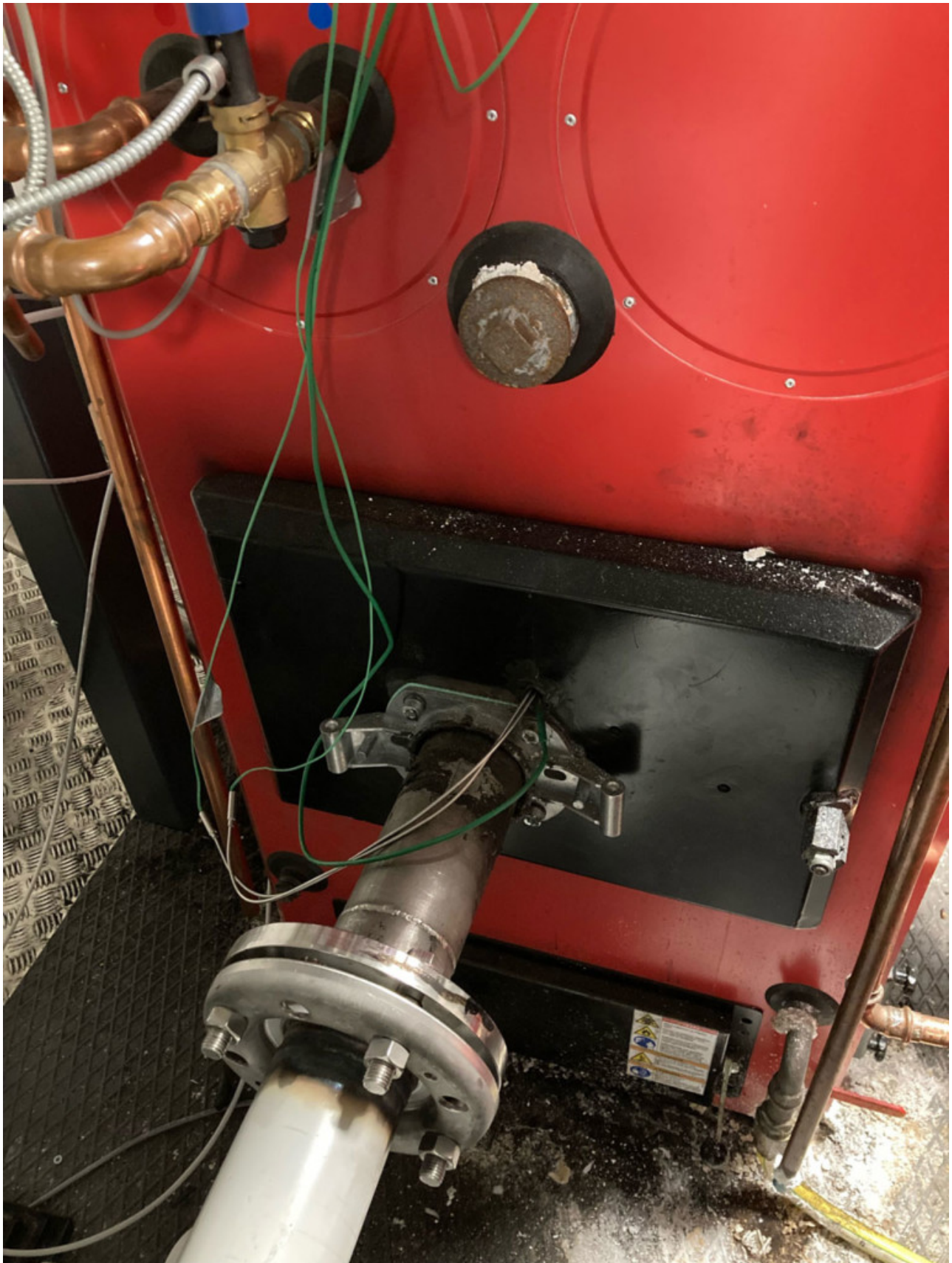

Figure 2. Extended door of the boiler.

Another change made to the boiler was that two additional screw-motor systems were added for the removal of biochar and for the feeding of biomass. One of these additional screw systems, which was installed on the left side of the boiler, was driven by a single-phase inductive motor. This motor was controlled by a programmable logic controller and a relay. The biomass feeding screw feeds the biomass that fall from a rotary feeder into the reactor where they will be heated to form biochar. The temperatures were taken at several points with thermocouples, then by using transmitters those signals were sent to the programmable logic controller where decisions were made in the program based on predefined conditions regarding what action to perform next. This action could be for example, when the screw system removes the char that has already been formed.

The small internal area and uneven internal heat distribution of the boiler have an impact on the pipe design. The temperature of most of the inside area is insufficient to start the active phase of pyrolysis. As a result, the reactor pipe has a bend (figure 3) over the area where the pellets are heated. During the procedure, this curved component is heated to a temperature above six hundred degrees, which guarantees the process to start. The entire internal area, which is built of steel, must be heated to heat this portion of the pipe to such an elevated temperature. This leads to the excess absorption of heat by the material during the drying phase, as well as difficulties in designing the feeding system. Due to this, the material overheats throughout the drying process, which makes it challenging to design the feeding system. The pipe has a component called a flange that limits heat transfer to other parts of the pipe to reduce overheating problems. The screw that removes the biochar makes it possible to regulate the biomass residence time in the pipe, which is important for the efficient operation of the reactor.



Figure 3. Reactor pipe with bend.



# Trials and prospects for the future

A trial was conducted in November 2022 with the first prototype pipe reactor using wood chips as biochar feedstock. The trial lasted an hour and fifteen minutes. At the end of the trial, the first set of biochar was produced. The furnace was heated between 590 °C to 640 °C and one bag (15 kilograms) of pellets was burned during the process. The biochar produced by the boiler was dark for the most part and possessed physical characteristics of normal biochar. A closer look at the molecular characteristics is still needed to determine if it is usable to improve the quality of soil for example.

The project will continue so that there will be an extension of the container that is housing all equipment, such as three water tanks, pipes, control cabinets and the modified boiler with the feeding and removal systems. The extension of the container is necessary to facilitate additional modifications, since there is limited space in which we are conducting trials. The extra space is needed to facilitate the complete installation of the desired modifications to the boiler as well as control boxes that contain programmable logic controller cards, fuses, relays, and other speed drives.

Despite challenges, the project has progressed smoothly thus far in a brief time and will continue to do so once we maintain a collaborative unity amongst all project members. The duration of the project is 1 year and 9 months, and with team effort it is likely that the targets that have been set will be met by the research unit and a complete system will be in full effect by then.

---

Daniel Kelly is a final year student at the Häme University of Applied Sciences studying Electrical and Automation Engineering. He works part time as a research assistant in HAMK Tech.

Valerii Matveev is an Electrical and Automation Engineering student who is at the end of his studies. He worked as a part-time research assistant in HAMK Tech.

## References

Ala-Talkkari. (n.d.). *Lämmityskattila, Veto 60 kW-stokerikattila Ala-Talkkarilta*. Veljekset Ala-Talkkari Oy. Retrieved February 2, 2023 from <https://ala-talkkari.fi/lammityskattila-veto-60-stokerikattila/> (<https://ala-talkkari.fi/lammityskattila-veto-60-stokerikattila/>).

Ayodele, A., Oguntunde, P., Joseph, A., & Dias Junior, M. de S. (2009). Numerical analysis of the impact of charcoal production on soil hydrological behavior, runoff response and erosion susceptibility. *Revista Brasileira de Ciência Do Solo*, 33(1), 137–146.  
<https://doi.org/10.1590/s0100-06832009000100015> (<https://doi.org/10.1590/s0100-06832009000100015>).

Ralebitso-Senior, T. K., & Orr, C. H. (2016). *Biochar Application: Essential Soil Microbial Ecology*. Elsevier.

Solar, J., de Marco, I., Caballero, B. M., Lopez-Uriónabarrenechea, A., Rodriguez, N., Agirre, I., & Adrados, A. (2016). Influence of temperature and residence time in the pyrolysis of woody biomass waste in a continuous screw reactor. *Biomass and Bioenergy*, 95, 416–423. <https://doi.org/10.1016/j.biombioe.2016.07.004>  
(<https://doi.org/10.1016/j.biombioe.2016.07.004>).

Wang, S., & Luo, Z. (2016). *Pyrolysis of Biomass*. De Gruyter.  
<https://doi.org/10.1515/9783110369632> (<https://doi.org/10.1515/9783110369632>).